

SCLP-UD

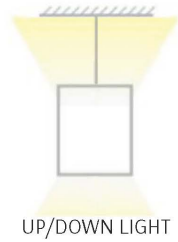

TECHNICAL SPECIFICATIONS:

- :: 4 Feet long
- :: Voltage: 120~277VAC 50/60Hz
- :: Wattage: Up/Down: 40W/20W
- :: Ambient Temperature: -13°F~104°F
- :: Dimmable: 0~10V dimmable
- :: CRI:>80
- :: Power Factor:>0.95
- :: Efficacy: 110LM/W
- :: IP Rating: IP20
- :: Life Span: 50,000 hours
- :: Housing: Anodized Aluminum
- :: Lens: Louver Lens



B12

LED PARABOLIC SUSPENDED COMMERCIAL LIGHTS

Optional Accessories



Coupling Bracket
(Not Included)
See Below



6 Ft. Cord
SJTW 18 AWG 5-Conductor
(Not Included)
See Page B34



Adjustable 6 Ft.
Suspension Kit
Select a Y-Connector
Key Hole Set
(Not Included)
See Page B34

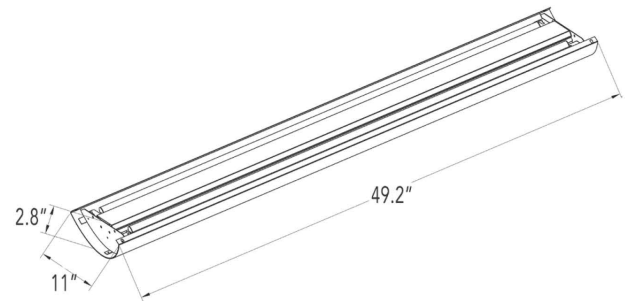

LED ARCHITECTURAL PARABOLIC SUSPENDED LIGHTS (UP/DOWN)

| CATALOG NO. | WATTS (UP/DOWN) | LUMENS (UP/DOWN) | COLOR TEMP | DIMENSIONS |
|-----------------------|------------------|------------------|------------|-----------------------------|
| SCLP-UD-4FT-60W-50K-D | 40W/20W | 4400LM/2100LM | 5000K | 49.2"(L) x 11"(W) x 2.8"(H) |
| SCLP-UD-4FT-60W-40K-D | 40W/20W | 4400LM/2100LM | 4000K | |
| SCLP-UD-4FT-60W-35K-D | 40W/20W | 4400LM/2100LM | 3500K | |
| SCLP-UD-CB | Coupling Bracket | | | |